

PHILIPS 795A MONO-KNOB SUPERHET FIVE

CIRCUIT.—A five-valve, including rectifier, superhet receiver for A.C. mains, operating on medium and long waves and a short-wave band of 16-50 metres.

Signals are fed to V1, a frequency changer, through an inductively and capacitatively coupled band-pass filter, and through a series resistance R32 which is incorporated to cut out parasitic oscillations which might occur while the receiver is switched to the shortwave band.

Coupling between V1 and V2, an H.F. pentode, is through an I.F. transformer tuned to 128 kcs., the coupling between the windings being variable and ganged with the tone control.

Coupling to V3 is by means of a second I.F. transformer, which has fixed coupling between its windings. The visual tuning indicator is connected in this stage, and an explanation of its working is given in "Special Notes."

The valve V3 is a double-diode triode, one diode being used for demodulation and the other to supply A.V.C. bias to the preceding valves in the orthodox manner.

The L.F. output is fed *via* a resistance and capacity stage to V4, the output pentode, which is tone-controlled in the grid circuit by C42 and R22. After ampli-

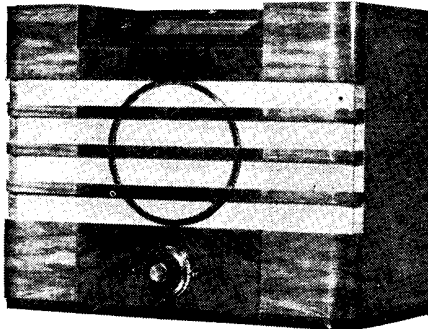

The Philips 795A covers a 16-58 metre band as well as medium and long waves. The Mono-knob control is quite easy to remove. (See p. 17).

fication signals are fed to the permanent magnet moving-coil loudspeaker *via* a matching transformer.

Part of the audio-frequency current is taken from the secondary of the output transformer and fed, through R21, R27, and CK1, to the cathode of V3, the purpose being to balance out any distortion that might be introduced into the speaker by the output valve. This is the

basis of the "Audioscopic" reproduction.

Mains equipment consists of transformer, full-wave rectifier, electrolytic condensers and a smoothing choke.

Special Notes.—The dial lamps are Philips type 8042. To remove them, slacken the bolt in each end of the carrier, which will then pivot about the right-hand bolt, making the lamps easily accessible.

The external speaker connections are on the primary of the output transformer, so that an extra speaker must have its own matching transformer.

The resistance R32 is located inside the connecting cap to V1.

The visual tuning indicator, a Mullard TV4, operates on the cathode-ray principle. It consists of a small triode working as a D.C. amplifier, a ray control electrode, and a target electrode which fluoresces or glows under electronic bombardment. A rectified D.C. potential is obtained from V3 and fed through the smoothing resistances and condenser R34, R35 and C27 to the control grid of the TV4 as negative bias. With no signal there is minimum glow; as the signal increases, increasing bias is applied, and the glow increases until a maximum is reached.

Switching Explanation.—In the circuit diagram there are two concentric rings of dots and circles in each switching diagram. The small circles represent contact springs on the stators, and the dots are used where there are no contacts.

The short radial lines between the two concentric rings represent shorting contacts on the rotor. Where there is a solid line joining two or more of these short radial lines the shorting contacts are actually connected together.

The dotted arcs show that adjacent contacts are shorted together (not permanently, but according to the position of the rotor).

The switches are shown in the open position. They work in a clockwise direction, the order of operation being: Short, medium, long waves, gramophone. With each new position, of course, *all*

PILOT U355 SUPERHET (Continued)

Position of Trimmers.—The aerial coil trimmers are on the front of the chassis between the wavechange switch and the side. The oscillator trimmers are on the other side of the switch. With the chassis upside down the order of the trimmers from the top downwards is: Aerial C 1, C 2, C 3; oscillator, C 12, C 11, C 10.

Medium Waves.—Connect the oscillator to the aerial and earth terminals through a .0002 mfd. condenser and tune it and the receiver to 200 metres and adjust C 11 and C 2 for maximum reading on output meter.

Tune to 500 metres, and while rocking

the gang condenser adjust C 8 for maximum output.

Return to 200 metres and check the adjustment of C 11 and C 2.

Short Waves.—Tune the oscillator and receiver to 16.6 metres and adjust C 12 and C 3 for maximum response.

Repeat two or three times to check the correctness of the adjustments.

Long Waves.—Inject and tune in a signal of 800 metres and adjust C 10 and C 1 for maximum reading.

Tune both the oscillator and the receiver to 1,875 metres and trim the padder, C 7, for maximum reading on the output meter. Return to 800 metres for check.

**Service
Sam
REPORTS:-**

That kit of ERIE Resistors is certainly useful. ERIE put in just the values I always seem to want. You're right. You can't beat 'em!

Carded Kits of Erie Resistors, 24 popular assorted 1-watt values on card. Boxed Kits, containing 20 assorted 1-watt values. Each Resistor retails at 1/-

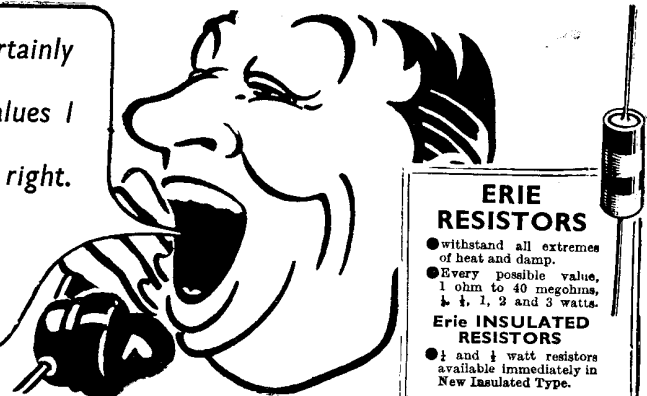

ERIE RESISTORS

- withstand all extremes of heat and damp.
- Every possible value, 1 ohm to 40 megohms, 1/4, 1/2, 3 and 3 watts.

ERIE INSULATED RESISTORS

- 1/2 and 1 watt resistors available immediately in New Insulated Type.

PHILIPS 795A MONO-KNOB SUPERHET

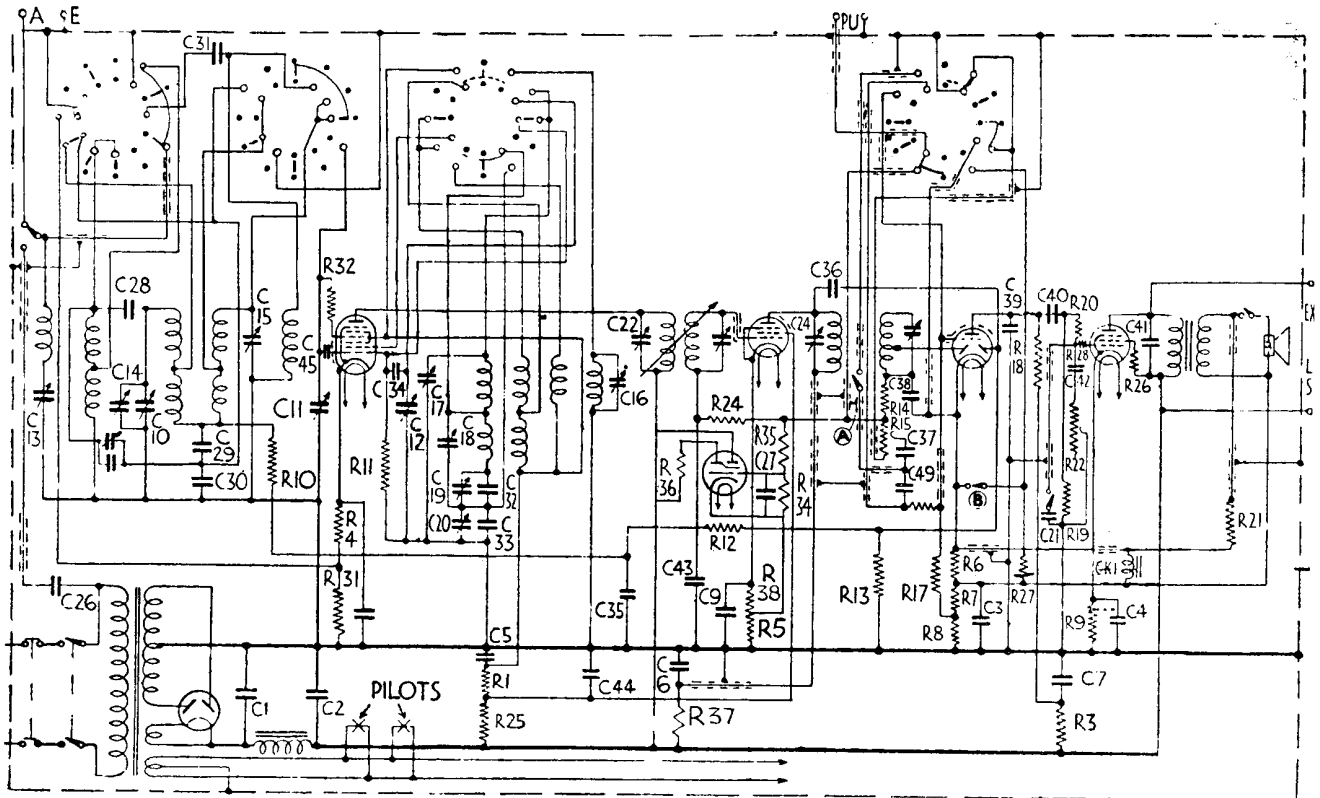

Circuit details of Philips' 795A. Switches A and B are shown in the "speech" or wider frequency response position. They are controlled by a single knob on the back of the chassis.

VALVE READINGS

No signal. Mono-knob top left position. 200 v. A.C. mains.

V.	Type.	Electrode.	Volts.	M./a.
1	Mullard FC4 Met. (7)	Anode ...	260	2.3
		Screen ...	70	2
		Osc. anode ...	70	5.1
2	Mullard VP4B Mc. (7)	Screen ...	240	0.4
		Screen ...	150	2.3
3	Mullard TDD4 Met. (7)	Anode ...	70	1.1
4	Mullard Pen A4 (7)	Anode ...	250	34
		Screen ...	260	3.8
5	Philips 1821 (4)	Filament ...	285	—

CONDENSERS

C.	Purpose.	Mfd.
1	H.T. smoothing32
2	H.T. smoothing32
3	V3 cathode bias shunt25
4	V4 cathode bias shunt25
5	V1 osc. anode and screen decoupling1
6	V2 anode decoupling1
7	V3 anode decoupling5
8	V1 cathode bias shunt05
9	V2 cathode bias shunt1
26	Mains aerial0005
27	TV4 grid filter05
28	Band pass coupling00001
29	V1 A.V.C. decoupling016
30	Band pass coupling025
31	Short wave coupling000016
32	Padding00065
33	Padding001375
34	V1 osc. grid0001
35	V1 A.V.C. decoupling1
36	A.V.C. diode coupling00001
37	L.F. coupling002
38	H.F. by-pass0001
39	V3 anode shunt0004
40	L.F. coupling02
41	Pentode compensating004
42	Tone control008
43	V2 A.V.C. decoupling1
44	V2 screen decoupling1
45	Osc. regeneration control000002
47	Image suppressor00002
49	L.F. coupling00025

RESISTANCES

R.	Purpose.	Ohms.
1	V1 osc. anode and screen decoupling ...	20,000
2
3	V3 anode decoupling ...	50,000
4	V1 cathode bias potr. ...	250
5	V3 bias bias potr. ...	800
6	V3 bias network ...	32
7	V3 bias network ...	3,200
8	V3 bias network ...	4,000
9	V4 cathode bias ...	160
10	V1 A.V.C. decoupling1 meg
11	V1 osc. grid leak ...	50,000
12	V1 A.V.C. decoupling ...	1 meg
13	A.V.C. diode load5 meg
14	Demodulator diode load, (part)1 meg
15	Volume control5 meg
16	V3 series grid ...	1.6 meg
17	V3 grid lead ...	1.6 meg
18	V3 anode load ...	1 meg
19	V4 grid leak8 meg
20	V4 grid stopper1 meg
21	Audioscopic tone filter ...	200
22	Tone control ...	5 meg
24	V2 A.V.C. decoupling ...	1.6 meg
25	V2 screen decoupling ...	1,600
26	V4 screen decoupling ...	32
27	Audioscopic tone filter ...	32
28	V4 grid stabiliser ...	1,000
31	V1 cathode bias potr. ...	2,500
32	V1 grid stabiliser ...	50
34	TV4 grid filter ...	1.6 meg
35	TV4 grid filter ...	5 meg
36	TV4 triode anode load ...	2 meg
37	V2 anode decoupling ...	1,600
38	V2 cathode bias ...	320
39	Audioscopic tone filter ...	10

the shorting strips move along one set of contacts clockwise.

Removing Chassis.—Practically all the work necessary on this model can be done without removing the chassis from the cabinet. Simply remove the fibre bottom, which is held by four screws.

Procedure for complete removal of the chassis is as follows: Remove the Mono-knob escutcheon, which is secured by springs; push a fine-pointed tool, such as a bradawl, through the two holes which will be found inside the front of the escutcheon to release these springs; then pull off the waverange switch. The "joystick" part of the Monoknob then goes through the large hole in the cabinet as the chassis is removed.

Raise the scale assembly to the limit of its travel, release the dial lamp

bracket from its securing bolts, and, holding the Bowden wire, slacken the pointer screw.

Next free the cable to the waverange indicator and unsolder the leads to the tuning indicator from the terminal strip on the loudspeaker, making a careful note of their positions for reconnection;

then, having removed the four bolts from underneath the cabinet, the chassis may be completely removed.

(Chassis layouts and alignment notes are on page 18.)

PHILIPS 795A MONO-KNOB SUPERHET (Cont.)

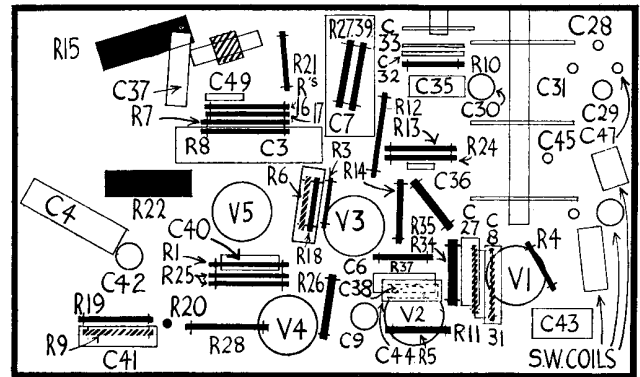
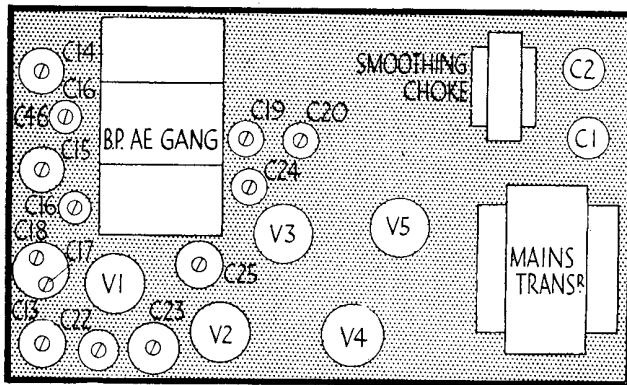

These layout diagrams of the Philips chassis (top on the left) do not have the usual controls indicated because the unusual Mono-knob combines all the adjustments.

CIRCUIT ALIGNMENT NOTES

IF Circuits.—Connect a modulated oscillator to the grid cap of V1 and an output meter across the external speaker terminals.

Shunt C24 with a 25,000 ohm resistance, and set the selectivity control to maximum. Inject a signal of 128 kc.s., trim C25 for maximum reading on output meter. Remove the shunt.

Shunt C23 with a 10,000 ohm resistance and a .1 condenser in series. Trim C22 for maximum reading on the output meter. Remove the shunt.

Shunt C25 with a 25,000 ohm resistance. Trim C24 for maximum reading. Remove the shunt.

Shunt C22 with a 10,000 ohm resistance and a .1 condenser in series. Trim C23 for maximum reading. Remove the shunt.

Medium Waves.—Inject a signal of 208 metres *via* a dummy aerial to the aerial and earth terminals, and tune it in; a template is available from the manufacturers so that correct adjustment of the

tuning condenser can be made. Adjust C17, C14 and C15 for maximum reading on output meter.

If the oscillator coils are badly out of gang, use should be made of an amplifier connected to the anode of V1 *via* a .00025 mfd. condenser and to the chassis.

The amplifier may be the gramophone side of any reliable receiver, and care should be taken to see that the amplifier grid lead is taken to the anode of V1. The anode lead of V1 is bared, and can be reached through a hole in the chassis to the right of the valve.

Having satisfactorily connected the amplifier the procedure is as follows: Shunt C22 with a 2,000 ohm resistance and a .1 mfd. condenser in series and inject a strong signal of 545 metres to the aerial and earth terminals.

Tune the receiver until it is heard from the amplifier, remove the amplifier and shunt and trim C20 for maximum reading on output meter.

The above should be repeated until the best results are obtained.

Long Waves.—Inject and tune in a signal of 760 metres (using template, if available). Adjust C18 for maximum response.

Connect up the amplifier as before and the shunt across C22; inject a strong signal of 1,875 metres, and tune it in. Then remove the amplifier and shunt and trim C19 for maximum reading.

Short Waves.—Inject and tune in a signal of 17.6 metres (using template, if available), and trim C16 for maximum reading on output meter.

Aerial Filter.—Switch the receiver to long waves and tune the condenser to maximum. Apply a strong signal of 128 kc.s. (the intermediate frequency), and trim C13 for minimum reading.

Image Filter.—Inject a signal of 403 metres, and tune it in. Leaving the tuning condenser at this setting, inject a strong signal of 300 metres and adjust C46 for minimum.

TESTING MAINS TRANSFORMERS

WHEN a mains transformer becomes unduly hot it may be due to either an overload caused by a partial short-circuit on an H.T. or L.T. secondary, or to an internal short circuit. As a first step it is advisable to disconnect all the secondary outputs and any earth connection to the core or frame, and run the transformer for sufficient time for heating to become manifest. If the temperature does not rise connect the earthing to the core.

A temperature rise then will indicate faulty insulation between a winding and the core or some other part of the "body" of the component.

When, however, the transformer runs cool with the earth connection it is safe to say that the cause of overheating must be sought in an external circuit. This can probably be traced by checking the voltages of the outputs with an A.C. voltmeter. If excess current is being taken the voltage will probably be lower than is correct.

If a Megger is at hand—and every service shop should possess one—a transformer can be tested for insulation without any "heat" test. The component should be disconnected from its receiver and insulation tests made from each winding to every other winding and frame.

When it is suspected that a transformer is not providing the voltage and current outputs it should, these can be tested by connecting the rated loads and measuring the voltages.

The general condition and efficiency of a transformer can be checked by measuring the current taken by the primary on no-load. This magnetising current should not be more than about a quarter of the full-load current. A large no-load current indicates shorted turns or insufficient iron in the magnetic circuit.

During current tests of this kind the meter scale chosen should read considerably more than the full-load current so as to reduce the risk of damage to the meter because of sudden surges.

Television Terms

"TELEVISION—Technical Terms and Definitions," is the title of a new book written by E. J. G. Lewis, author of "Radio Receiver Servicing," and regular contributor to BROADCASTER. This volume is published at 5s. by Pitman's, and is available from the Technical Book Department, Odhams Press, Ltd., Long Acre, London, W.C.2, at 5s. 6d., post free.

Sets with Reaction

It is customary to gang sets with reaction with that control at minimum. It should not be forgotten, however, that in a modern set reaction is needed only when greatest sensitivity and selectivity are sought, which is just when accurate ganging is most needed.

When trimming the circuit to which reaction is applied, therefore, it is advisable to increase reaction gradually. The previous circuit should then be retrimmed with the set almost oscillating.